

5DXLR User Manual



SAFETY

Please read this instruction manual before operating this product.

Please store this instruction manual in the carry case for future reference.

CAUTION: Class 2 Laser Product

Do not stare directly into the laser beam from apertures.

Do not disassemble the instrument or attempt to perform any internal servicing as this will void your warranty. No user serviceable parts included.

Only approved and authorised service technicians can carry out warranty repairs.

ITEM CHECKLIST

Please ensure the following items are included with your laser.
If anything is missing please contact your retailer.

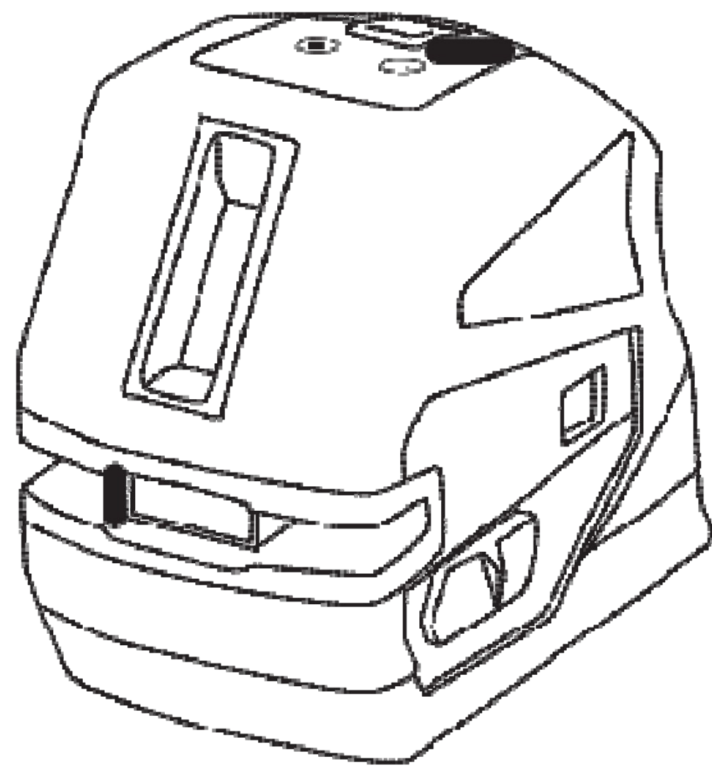

5DXLR

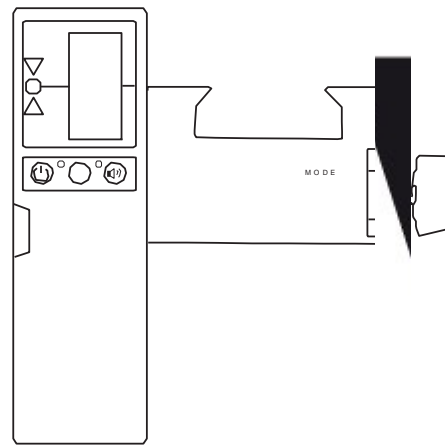

Detector and clamp
(Optional)

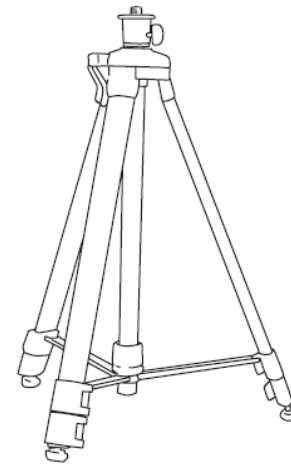

Indoor tripod

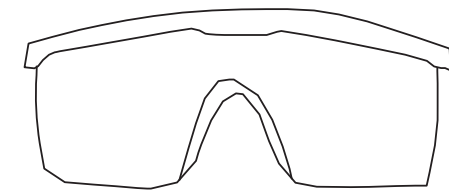

Laser glasses

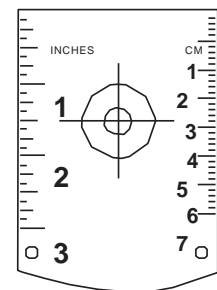

Laser target

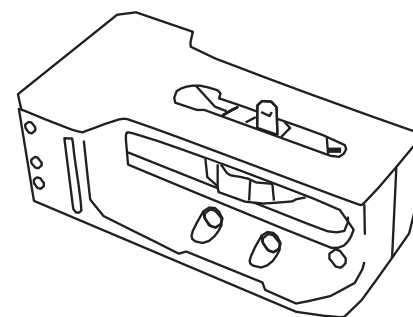

Magnetic base

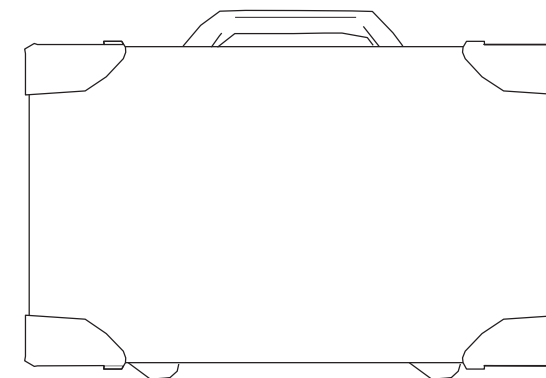

Carry case

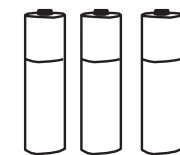

Batteries

PRODUCT OVERVIEW

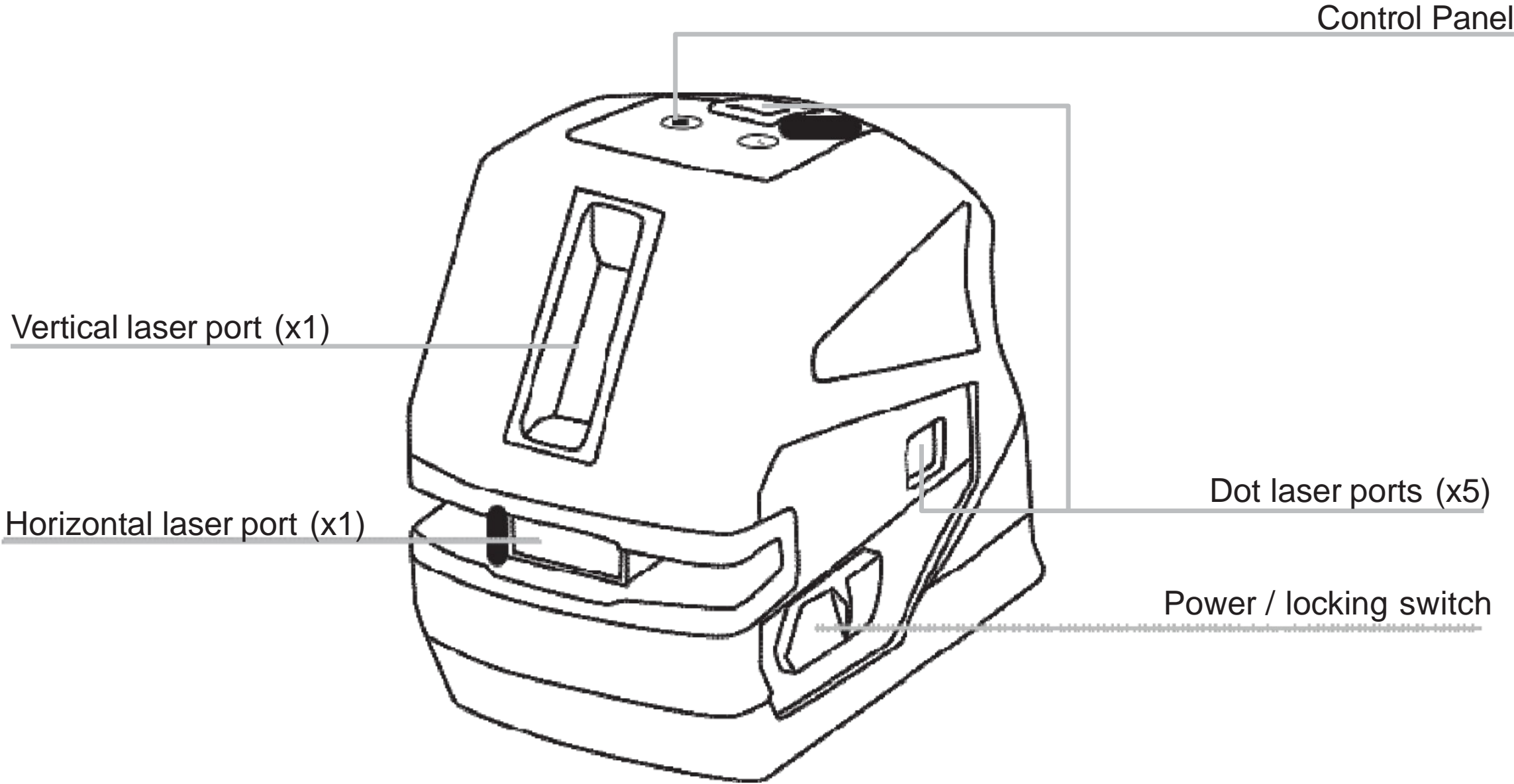

CONTROL PANEL

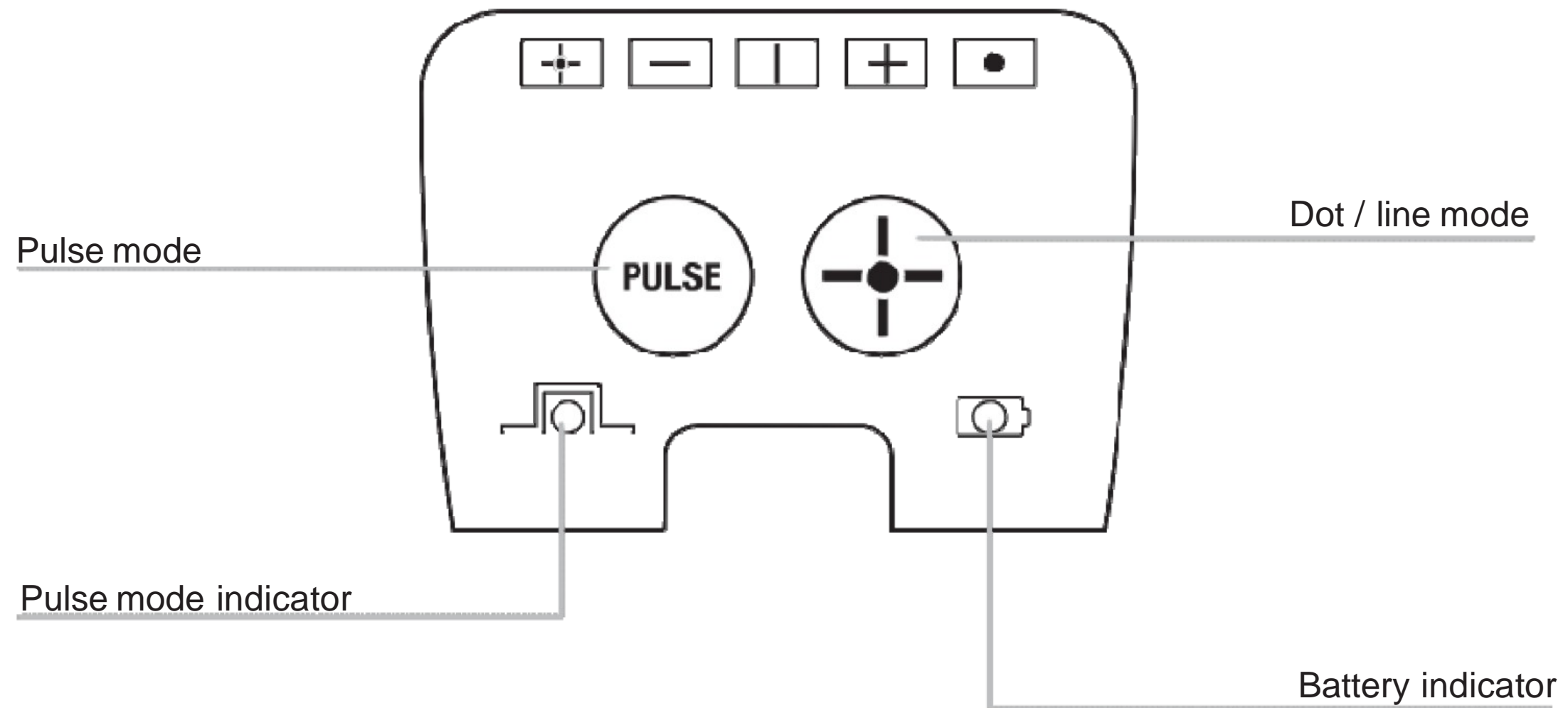

DETECTOR CONTROL PANE

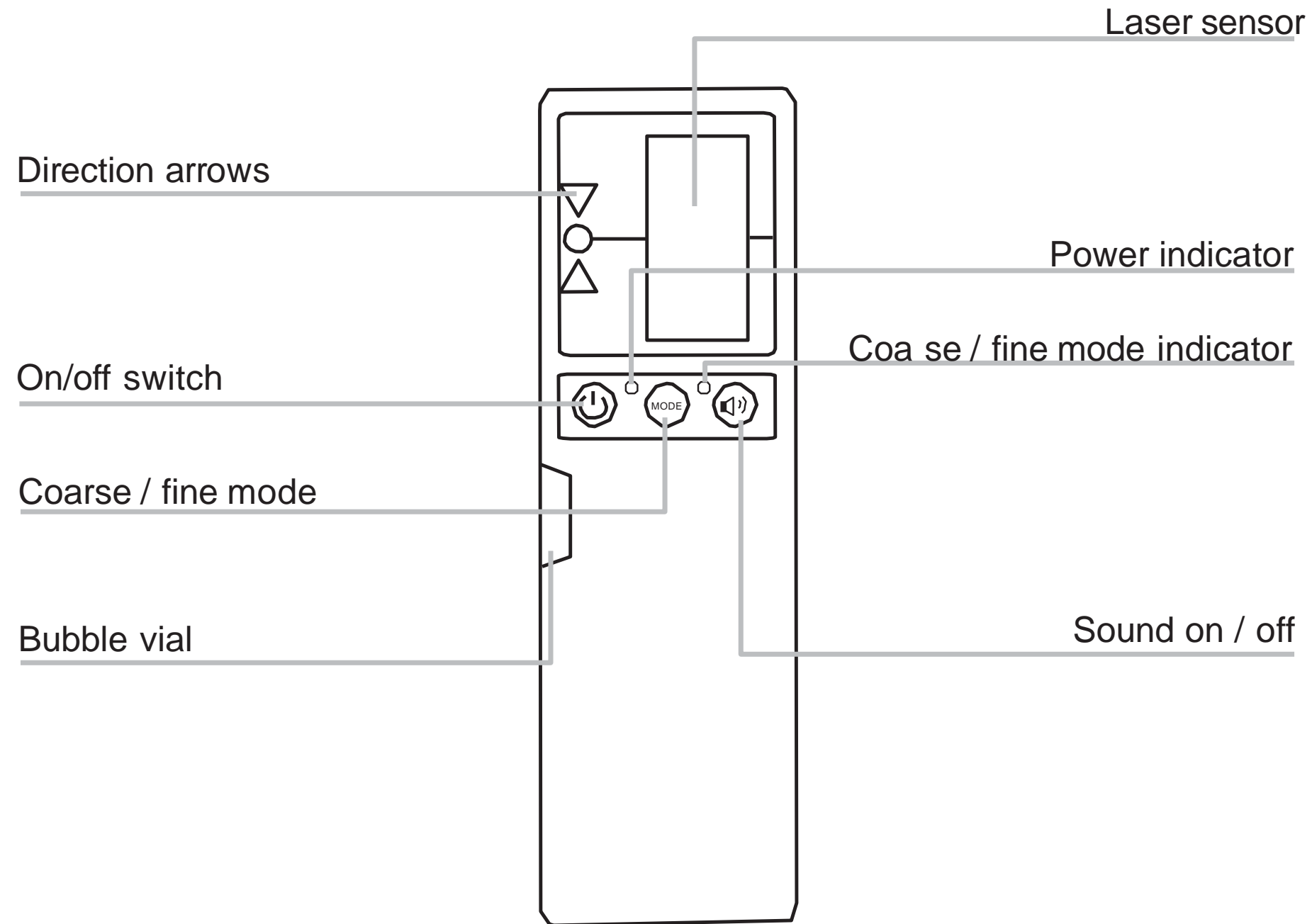

USING YOUR LASER

Power Supply

The FDG232 is powered by four AA alkaline batteries.

Setting Up

- Select a place as close as practical to the work site. Ensure the location is clear of traffic.
- Place the laser on a level surface such as a bench or mount.

Operation

- To turn the unit on turn the *power* switch to “on” position. Self levelling will commence and all dot and line beams will appear.
- If the unit is outside the self levelling range the unit will not level causing the speaker to beep and the laser beam to turn off.
- Press the *dot / line mode* button on the control panel to cycle through the active beams.

Using Your Detector

- Press the *pulse* button on the control panel on top of the laser to enter into pulse mode.
- Switch the detector on and move it into the path of the laser beam.
- Hold the detector upright for horizontal beams. Rotate the detector 90° for vertical beams. The direction arrows will indicate the position of the laser beam. The centre LED will indicate alignment with the beam.

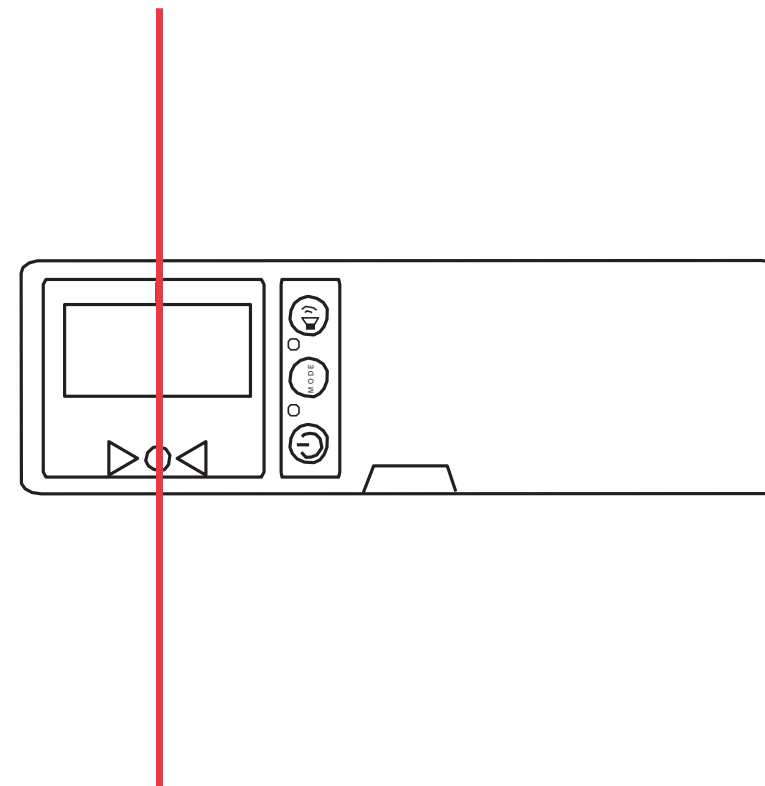
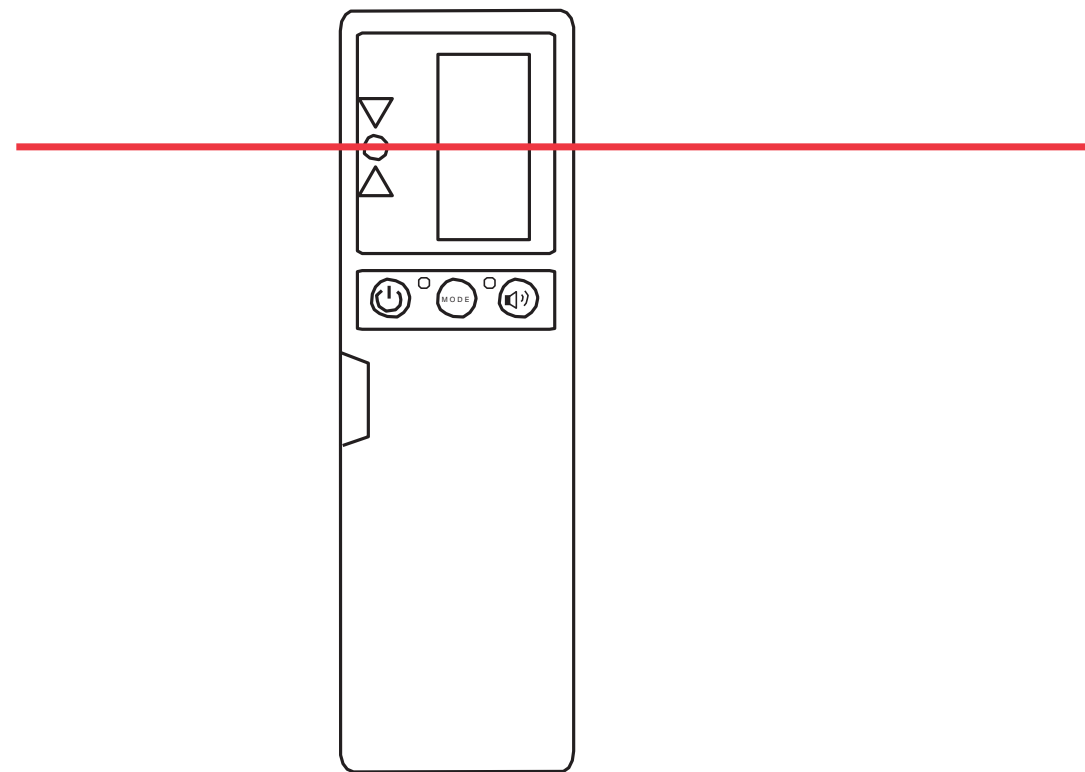

CARE AND MAINTENANCE

- Reflective surfaces such as glass may reflect the beam, causing two beams to strike the detector at the same time. This may create inaccurate reference points.
- This is a precision instrument and should always be transported within the carry case provided.
- Always turn the on/off lock to “off” when transporting the unit.
- Whenever possible, store the instrument in a dry, shady location.
- The FDG232 should be calibrated every 6 months, if ongoing accurate levelling is required or an impact has occurred.
- The operator should check the FDG232 for accuracy before precision levelling is attempted.
- Clean the instrument with a dry, soft cloth after use in dusty, damp or wet conditions before storing.
- Smudges and fingerprints may be removed with a damp tissue or a soft, lint-free cloth

SPECIFICATIONS

Specifications	FDG232
Accuracy	±2mm at 10m
Range	50m (detector)
Levelling range	±4°
Laser class	Class II Red
Battery life	10 hours
Battery type	4x AA
Dots	5
IP rating	54
Weight (kg)	0.55
Dimensions (mm)	112x113x63